

## Radio systems

### **WARNING!**

**Before working on the electrical system disconnect the battery Ground (GND) strap.**

This chapter includes information concerning the radio systems from 08.98

### **Notes:**

- ◆ *When faced with complaints it is absolutely necessary to know the functions and how to operate the radio system.*
- ◆ *The radio units are equipped with an electronic anti-theft system with a fixed code.*

⇒ *Operating instructions*

- ◆ *As a matter of principle only radio sets and parts from the Volkswagen and Audi program (Messrs. Votex) should be used, only then can trouble-free fitting and optimal reception be guaranteed.*
- ◆ *When retrofitting, repairing or troubleshooting*

⇒ *Electrical Wiring Diagrams, Troubleshooting & Component Locations*

- ◆ *If a VW radio up to 07.98 is to be fitted in a vehicle designed for radio generation from 08.98 then observe the relevant notes ⇒ [Page 91-18](#).*
- ◆ *If a VW radio from 08.98 is to be fitted in a vehicle designed for radios up to 07.98 then observe the relevant notes ⇒ [Page 91-19](#).*

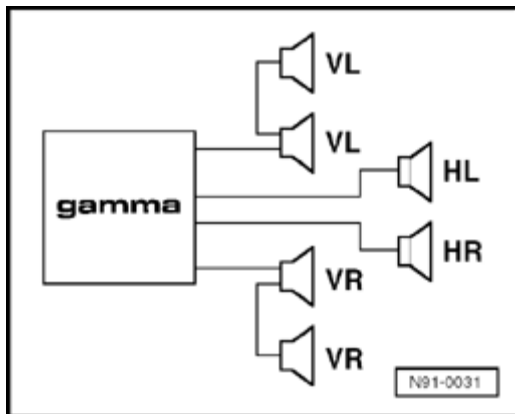

## Radio system from 08.98

The radio system is comprised of the radio unit, 2 treble loudspeakers in the dash panel, 2 bass loudspeakers in door trim and 2 wide band loudspeakers in rear.

### Bass loudspeakers front right and left

- ◆ Passive loudspeaker system
- ◆ Fitted in door tray
- ◆ Diameter 168 mm

### Treble loudspeakers, front right and left

- ◆ Passive loudspeaker system
- ◆ Fitted in dash panel
- ◆ Dome treble loudspeakers 100 mm diameter on a base plate.
- ◆ Connected to bass loudspeaker

### Wide band loudspeakers rear right and left

- ◆ Passive loudspeaker system
- ◆ Installed in side panel trim
- ◆ Diameter 100 mm

The radio is available in the optional equipment program with only 4 loudspeakers. Whereupon with this option there are 2 wide band loudspeakers in the dash panel and 2 wide band loudspeakers in the rear.

#### **Wide band loudspeakers front right and left**

- ◆ Passive loudspeaker system
- ◆ Fitted in dash panel
- ◆ Diameter 100 mm

#### **Wide band loudspeakers rear right and left**

- ◆ Passive loudspeaker system
- ◆ Installed in side panel trim
- ◆ Diameter 100 mm

#### **Antenna**

- ◆ Passive rod antenna or
- ◆ Active windscreen antenna

### Contact assignment of the multi-pin connectors I, II, III on the rear of the radio

Multi-pin connector I, -T20- consists of 3 parts that are marked with different colors:

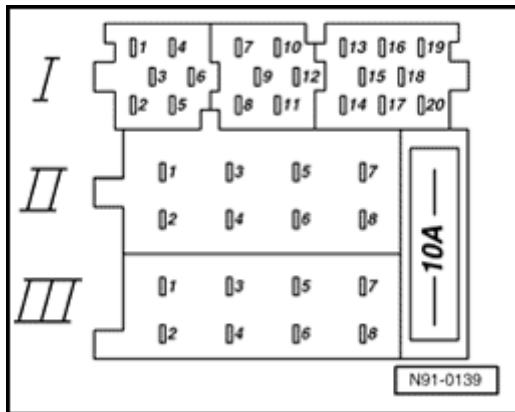

#### Multi-pin connector I, part 1, yellow

This connector is not used.

#### Multi-pin connector I, part 2, green

- 7 - Telephone input signal, TEL+
- 8 - Second display, CLOCK
- 9 - Second display, DATA
- 10 - Second display, ENA
- 11 - Remote control, REM
- 12 - Telephone input signal, TEL-

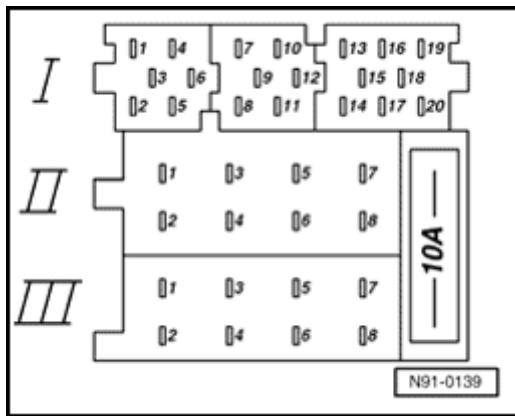

### A Multi-pin connector I, part 3, blue

This connector is not used.

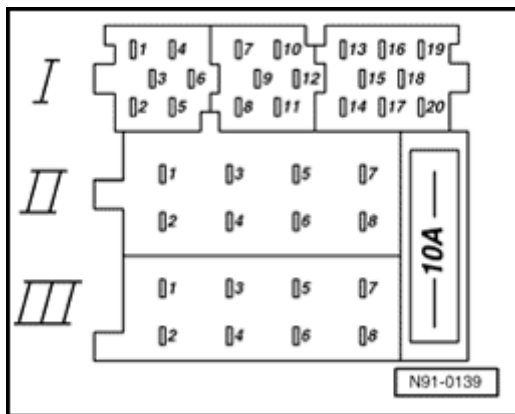

### A Multi-pin connector II, -T8a-, 8-pin, brown

- 1 - Loudspeaker + rear right
- 2 - Loudspeaker - rear right
- 3 - Loudspeaker + front right
- 4 - Loudspeaker - front right
- 5 - Loudspeaker + front left
- 6 - Loudspeaker - front left
- 7 - Loudspeaker + rear left
- 8 - Loudspeaker - rear left

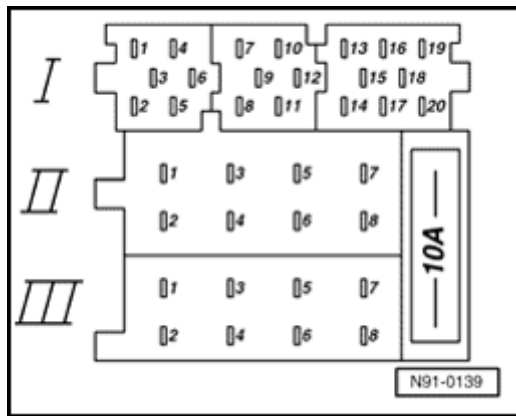

#### A Multi-pin connector III, -T8-, 8-pin, black

- 1 - Gala (volume adaption)
- 2 - Telephone mute circuit
- 3 - Self-diagnosis/K wire
- 4 - Connection for ignition key controlled switching on and off (SU contact)
- 5 - Anti-theft system control signal, SAFE (terminal 30)
- 6 - Illumination (terminal 58b)
- 7 - Battery + (terminal 30)
- 8 - Battery - (terminal 31)

## Radio, removing and installing

### Note:

Obtain the code number from the customer before removing the radio. If the radio is replaced, always activate the anti-theft coding ⇒ [Page 91-11](#) . The customer must be informed of the new code number.

### Special tools, testers, measuring tools and auxiliary items required

A

- ◆ 3316 Releasing tool

The radio release tool 3316 consists of two identical parts.

### Removing

A

- Slide radio release tool 3316 into the release slots -arrows- until they locate.

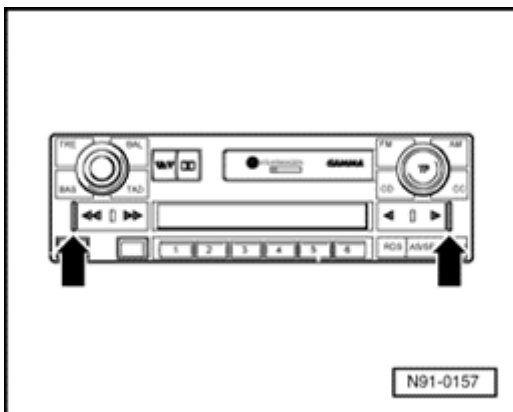
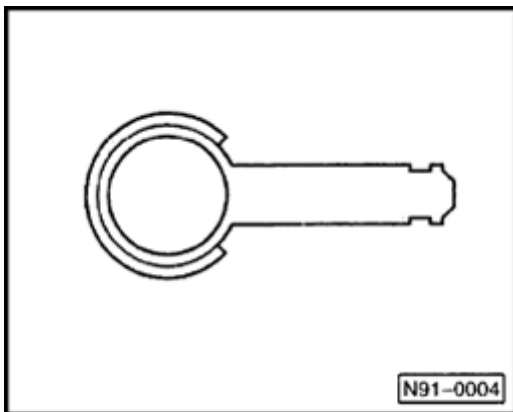

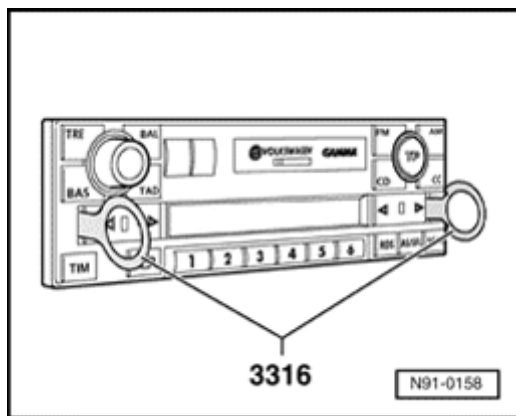

A

- Pull radio out of the dash panel using the grip rings of the release tools.

#### Notes:

- ◆ *When doing this the radio release tool 3316 must not be pushed to the side or tilted.*
- ◆ *To remove the release tools from the radio the locating lugs on the side of the radio must be pressed inwards.*

#### Installing

- Connect plug to radio.
- Slide radio level into the dash panel, until it locates in the assembly frame.